

2500 Series Stainless Steel Single Cover Trims

Stainless steel floor access cover trims for heavy duty timber strip floors

Features

- Covers can be fitted quickly and unobtrusively into all types of hard floor finish: ceramic tiles, marble, terrazzo, resin or parquet.
- Lifting blocks are anchored to the inner frame. Stainless steel securing bolts are stiletto heel proof.
- Quality control to BS EN ISO 9001:2000.

General notes on 2500 series floor access covers

Size – All covers are made to measure using the Howe Green patented system. This allows the manufacture of any size between the stated maximum and minimum dimensions. Sizes that may be thought 'non-standard' can therefore be obtained without delay and without cost surcharge. The versatile nature of the Howe Green system allows any configuration of ducts and branches to be created.

Weight – The weight of the access cover should be taken into account where ease of handling is an important consideration. In all cases reference should be made to the Manual Handling Operations Regulations 1992, which implement European Directive 90/269/EEC. If loads are excessive, consideration should be given to the use of hydraulic lifters, or our HSE 75 range.

SS

S



2500 Series Stainless Steel Single Cover Trims

floor access cover trims for pedestrian traffic

Typical floor finishes

All types of heavy duty timber floors.

Performance

Pedestrian traffic (including wheeled trolleys, sack trucks etc.) only.

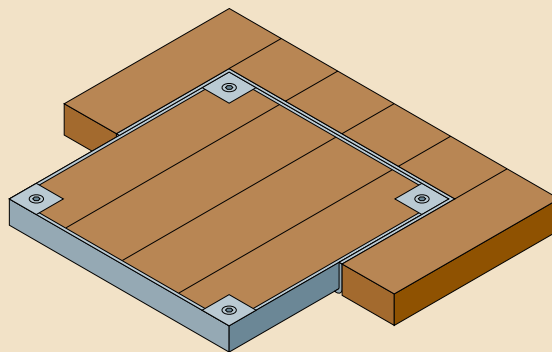

Cross section showing timber sub floor (scale 1:2)

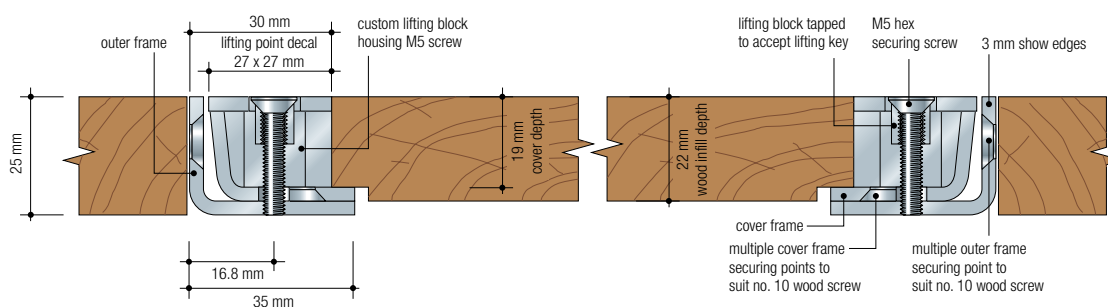

Typical specification clause for 2500 series

Recessed floor access/duct* cover and frame trims shall be Howe Green Ltd 2500 series manufactured from stainless steel and fitted with stainless steel securing bolts. Overall outer frame sizes shall be† mm x† mm. Covers are to be supplied with† sets of combined lifting/securing keys. All to be manufactured and supplied by Howe Green Ltd, Marsh Lane, Ware, Hertfordshire, SG12 9QQ, Great Britain, and installed in accordance with the manufacturer's installation details and sitework guide.

* Delete as appropriate. † Insert appropriate numbers & quantities

Size

Overall frame size = clear opening + 70 mm e.g. 250 x 250 mm
clear opening = 320 x 320 mm
overall frame. Subject to correct infill/installation (see separate guide).
See also general notes on other side.

Maximum / minimum sizes

